



SXA4



TYPICAL APPLICATIONS	High pressure cleaners, ironing steam generators, industrial machines, cutters
FUNCTIONS	■ DPST, illuminated or not
PROTECTION DEGREE	IP 54, IP 55 for version with silicone
CYCLE No.	50.000
CUT OUT	30x22 mm
AMBIENT TEMPERATURE	125 °C
GWT	850 °C
GWT NO FLAME (<2 sec)	750 °C on demand



DRAWING



TERMINAL



FUNCTION

O-RING

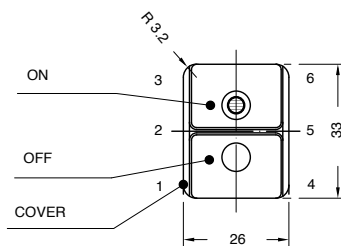
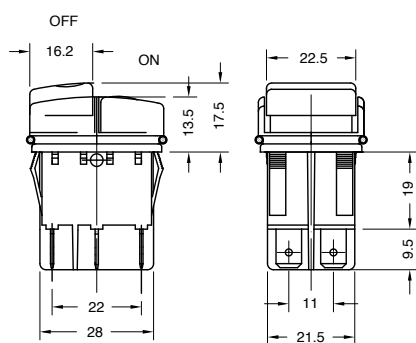

1 Standard

2

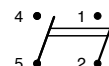

4 With silicone

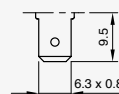

8

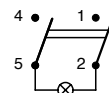

GASKET

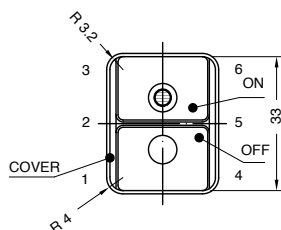
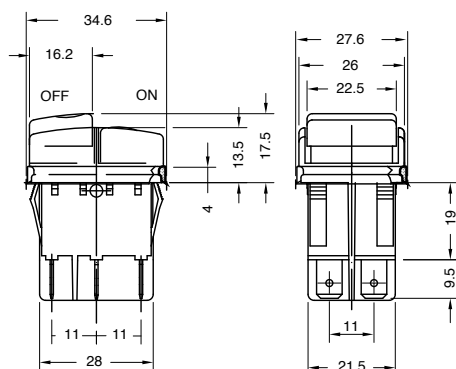

3 Standard

5 With silicone

