

G5	T	16	C	Z	200	A	01	B	K	280
Switch Type	Temperature Grade	Electrical Rating	Terminal Type	Circuit Code	Max Operating Force at Pin Plunger	Lever Position	Lever Type	Housing Color	Mounting Holes	Special Designator

G5 Series

Basic Micro Switch

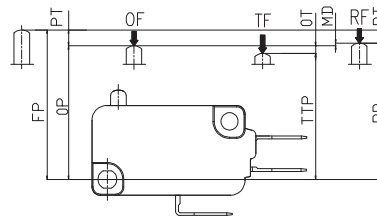

Features

- Tight Configuration, Small Contact Gap, Snap Action, High Sensitivity and Small Operating Travel
- Long Life, High Reliability
- Global Safety Approvals
- Variety of Terminals
- Wide Range Operating Force (7gf-600gf)
- Wide Range Temperature Grade (-40°C ~ +150°C), 200°C Optional
- With Optional PTI Grade (175v, 250v, 600v)
- Variety of Levers
- Widely Used in Home Appliances, Electronic Equipments, Automatic Machines, Communication Equipments, Auto Electronics, Apparatus and Instrument, Power Tool etc

Applications

- Home Appliances
- Electronic Equipments
- Automatic Equipments
- Communication Equipments
- Auto Electronics
- Apparatus and Instruments
- Power Tools

Parameters

Operating Speed		0.1 mm-1 m/s (Related with actuator forms)
Operating Frequency		Mechanical 60 cycles/min; Electrical 15 cycles/min.
Insulation Resistance		≥ 1 00M Q (500VDC)
Contact Resistance		≤ 100m Q (Initial value)
Voltage Resistance	Between each terminals of the same polarity	AC1 000V, 50/60HZ, 1 min.
	Between current carrying metal part and ground and between each terminal and non-current carrying metal parts	AC1500V, 50/60HZ, 1 min.
Vibration Resistance		10-55HZ, 1.5mm Double amplitude
Shock Resistance		Destruction: OF > 1.0N: 1 000m/s ² (approx. 100G) max. OF ≤ 1.0N: 400m/s ² (approx. 40G) max. Destruction: OF > 1.0N: 200m/s ² (approx. 20G) max. OF ≤ 1.0N: 1 00m/s ² (approx. 10G) max.
Service Life		Mechanical ≥ 10,000,000 cycles or 1,000,000 cycles or 50,000 cycles Electrical ≥ 50,000 cycles or 100,000 cycles Depends on Part No.
Unit Net Weight		6.2g Approx. 6.2g (No lever)

G5	T	16	C	Z	200	A	01	B	K	280
Switch Type	Temperature Grade	Electrical Rating	Terminal Type	Circuit Code	Max Operating Force at Pin Plunger	Lever Position	Lever Type	Housing Color	Mounting Holes	Special Designator

Temperature grade

- S** 25T85 (for "05" rating only)
- T** 25T125
- H** 25T150
- B** 25T125 Only for "08" rating and contact gap>3mm
- F** 25T85, IEC IP64 Only for rating "10"

10
UL/CUL:
1A 30VDC
10A 1/2HP 125/250VAC
 (Above only for "H" temperature grade)

UL/CUL:
11A 1/3HP 125/250VAC
0.5A 125VDC 0.25A 250VDC
4A 125VAC L
ENEC/CQC
10(3)A 125/250VAC,0.5A 125VDC 0.25A 250VDC
25T125 μ 5E4
 (Above only for "T" temperature grade) C1, C2, E, E1, E2, D, D1, D2, F, F1 Terminal only.

Electrical Rating

05
ENEC/CQC:
0.1A48VDC
0.1A 125/250VAC
5(2.S)A 125/250VAC,5E4,μ

UL/CUL:
0.1A48VDC
0.1A 125/250VAC
5A 1/10HP 125/250VAC

"S" Temperature grade only. Only apply to C, C1, C2, H, E1, E2, D, D1, D2, S, S1, S2, F, F1)

08
ENEC/CQC
8(10)A 250VAC,5E4,25T125
UL/CUL
10.1A1/2HP 250VAC

Above only for "B" temperature grade and switch of contact gap>3mm) and only with C2 and D2 terminals; "300"~"500" OF only

10(4)A 250V AC
25T85 μ 5E4
IP64
 Only for G5F "IP64" waterproof grade

16
ENEC/CQC:
16(4)A 250VAC μ 5E4
UL/CUL:
16A 1/2HP
125/250VAC

22
ENEC
16(13)A 250VAC μ 5E4
22(8)A 250VAC μ 1E4
CQC
22(8)A 250VAC μ 1 E4
UL/CUL
22A HP
125/250VAC

26
ENEC/CQC:
26(10)A 250VAC, 0.02A 250VAC, 25E3 μ

Inner Construction

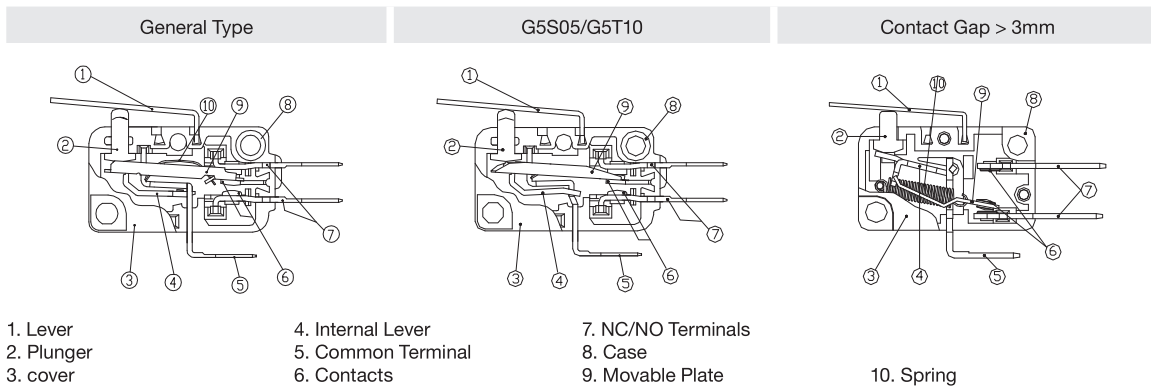

G5	T	16	C	Z	200	A	01	B	K	280
Switch Type	Temperature Grade	Electrical Rating	Terminal Type	Circuit Code	Max Operating Force at Pin Plunger	Lever Position	Lever Type	Housing Color	Mounting Holes	Special Designator

Mounting Hole Dimensions

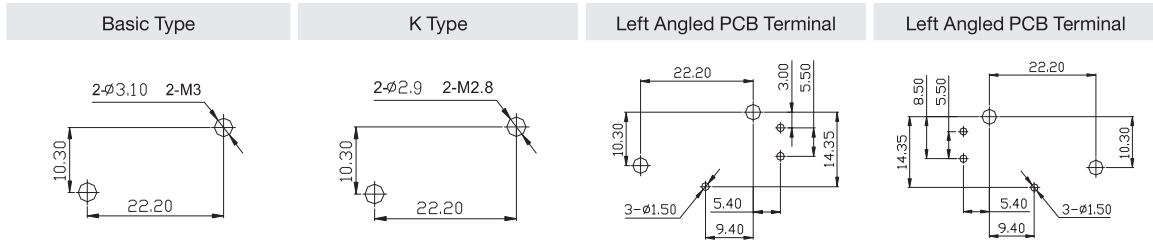

Housing Outline Characteristics

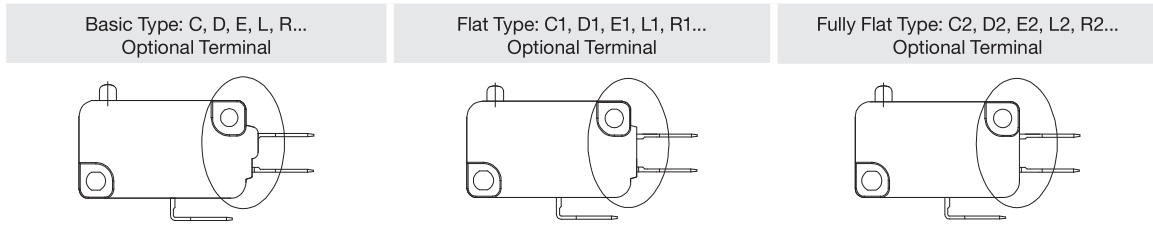

Terminal for Basic Type Housing

- C** Basic Type Housing with 250# Quick Connect Terminals, T=0.8(C)
- D** Basic Type Housing with 187# Quick Connect Terminals, T=0.8(D)
- E** Basic Type Housing with 187# Quick Connect Terminals, T=0.5(E)

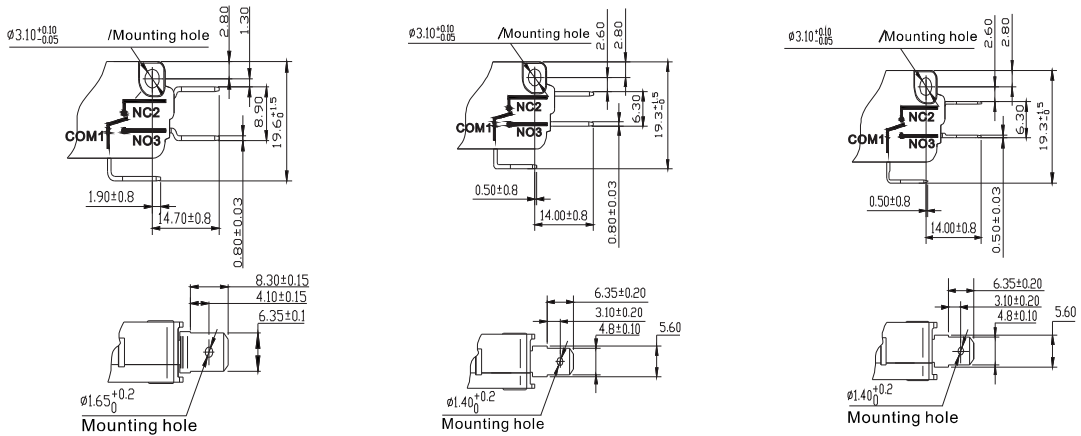

G5	T	16	C	Z	200	A	01	B	K	280
Switch Type	Temperature Grade	Electrical Rating	Terminal Type	Circuit Code	Max Operating Force at Pin Plunger	Lever Position	Lever Type	Housing Color	Mounting Holes	Special Designator

Terminal for Flat Type Housing

C1 Flat Type Housing with 250# Quick Connect Terminals, T=0.8(C1)

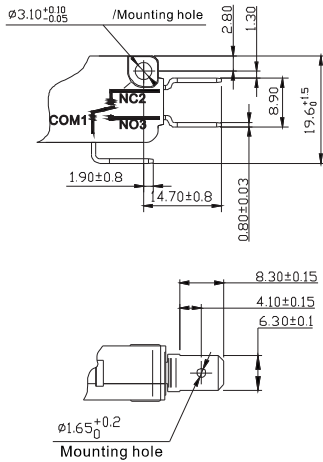

D1 Flat Type Housing with 187# Quick Connect Terminals, T=0.8(D1)

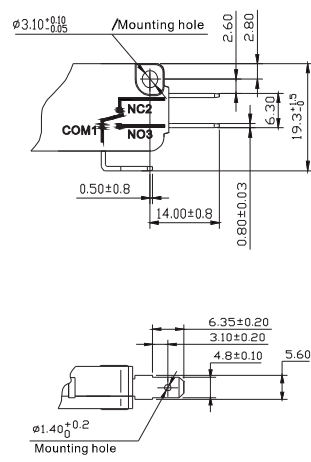

E1 Flat Type Housing with 187# Quick Connect Terminals, T=0.5(E1)

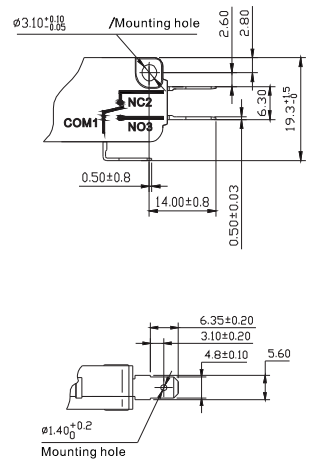

Terminal for Flat Type Housing

B2 Fully Flat Type 250# Quick Connect Terminals, T=0.8

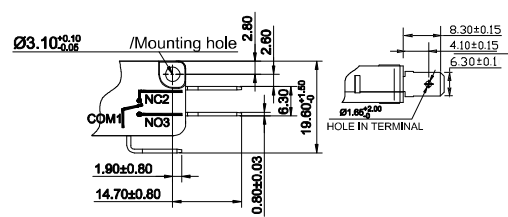

C2 Fully Flat Type Housing with 250# Quick Connect Terminals, T=0.8(C2)

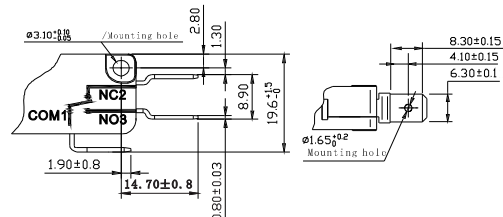

D2 Fully Flat Type Housing with 187# Quick Connect Terminals, T=0.8(D2)

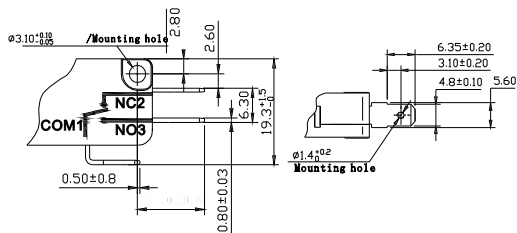

E2 Fully Flat Type Housing with 187# Quick Connect Terminals, T=0.5(E2)

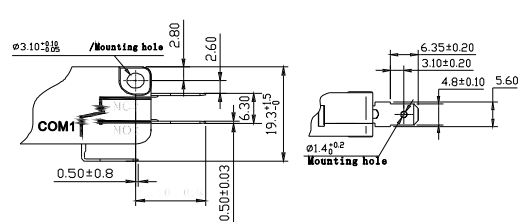

G5	T	16	C	Z	200	A	01	B	K	280
Switch Type	Temperature Grade	Electrical Rating	Terminal Type	Circuit Code	Max Operating Force at Pin Plunger	Lever Position	Lever Type	Housing Color	Mounting Holes	Special Designator

Terminal for Flat Type Housing

L Left Angled PCB Terminal	R Right Angled PCB Terminal	T Screw Terminal
-----------------------------------	------------------------------------	-------------------------

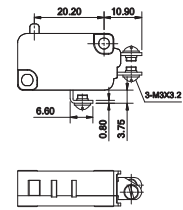
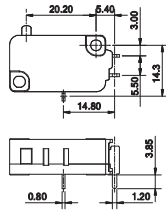
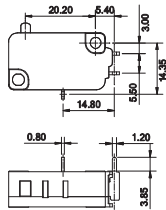

F Slant Screw Terminal	S Standard Solder Terminal	K Rectangle Hole Solder Terminal
-------------------------------	-----------------------------------	---

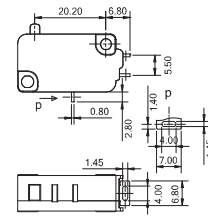
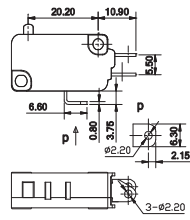
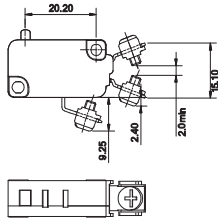

M Short Solder Terminal	H RAST-5	N RAST-7
--------------------------------	-----------------	-----------------

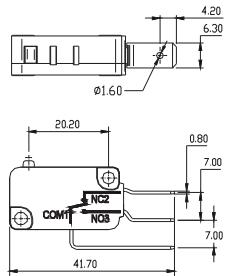
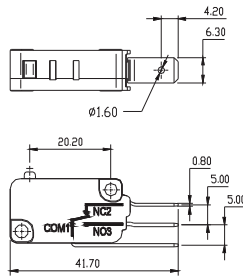
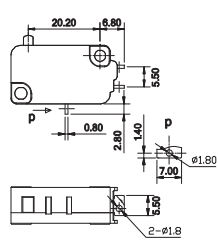

P Straight PCB Terminal	P Type Bended PCB Terminal	IP67 Water Proof and Dust Proof (Exclude Terminals)
--------------------------------	-----------------------------------	---

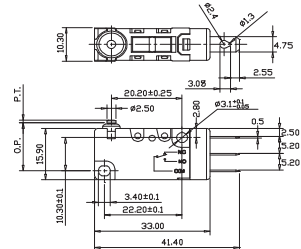
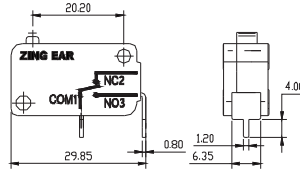
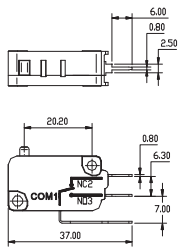

Circuit Configuration

Common Terminal Type	Z SPDT	C SPST-NC	P SPST-NO
----------------------	---------------	------------------	------------------



G5	T	16	C	Z	200	A	01	B	K	280
Switch Type	Temperature Grade	Electrical Rating	Terminal Type	Circuit Code	Max Operating Force at Pin Plunger	Lever Position	Lever Type	Housing Color	Mounting Holes	Special Designator

Max Operating Force at Pin Plunger

- 015 15gf**
Note: Only apply to G5S05, G5W11 (Rating1) series.
- 025 25gf**
Note: Only apply to G5S05, G5W11 (Rating1) series.
- 050 50gf**
0.49N
Note: Only apply to G5S05, G5W11 (Rating1 & Rating 2) series.
- 100 100gf**
0.98N
Note: 16A and 22A Minimum OFI s 100gf.
- 200 200gf**
1.96N
Note: G5S05, G5T10, G5W11 Series
200gf/with maximum OF is 200gf
- 300 300gf**
2.94N
Note: Not apply to G5S05, G5T10, G5W11 Series.
- 400 400gf**
3.92N
Note: Not apply to G5S05, G5T10, G5W11 Series.
- 500 500gf**
4.90N
"B" Temperature grade only
- 1800 1800gf**
17.64N
"G5D Door switch" only

Other Levers

08 Lever 08# 	09 Lever 09# 	137 Lever 137# 	146 Lever 146#
152 Lever 152# 	153 Lever 153# 	165 Lever 165# 	182 Lever 182#

Lever Position

- No lever
Pin Plunger
- A** Far From Pin Plunger
 - B** Close to Pin Plunger
 - F** Push Rod
G5D Door switch only
 - J** Screw Push Rod
G5D Door switch only

Housing Color

- Grey
- B** Black
 - M** 750 °C
Glow Wire 750 °C

G5	T	16	C	Z	200	A	01	B	K	280
Switch Type	Temperature Grade	Electrical Rating	Terminal Type	Circuit Code	Max Operating Force at Pin Plunger	Lever Position	Lever Type	Housing Color	Mounting Holes	Special Designator

Lever Position

Metric ϕ 3.1 mm

- K** ϕ 2.9 mm
- U** Alloy base with inner mounting hole
Only for G5D Door Switch
- V** Alloy base with outer mounting hole
Only for G5D Door Switch
- W** Alloy base with two switches
Only for G5D Door Switch

Special Designator

Here means a special designator letter. Refer to products specification for detailed differences.

- H** Rast-5 250# terminal
- N** Rast-7 250# terminal
- P** Straight PCB Terminal
- A** Contact gold plated

Dimensions and Operating Characteristics

Pin Plunger

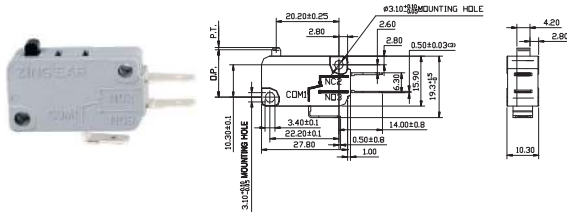

Part No.	Parameters							
	OF Max. (N)	OF Max. (gf)	RF Min. (N)	RF Min. (gf)	PT Max. (mm)	OT Min. (mm)	MD Max. (mm)	OP (mm)
G5□□□-E1Z015	0.15	15	0.03	3	1.6	0.8	0.4	14.7±0.5
G5□□□-E1Z025	0.25	25	0.05	5	1.6	0.8	0.4	14.7±0.5
G5□□□-E1Z050	0.49	50	0.10	10	1.6	0.8	0.4	14.7±0.5
G5□□□-E1Z100	0.98	100	0.25	25	1.6	0.8	0.4	14.7±0.5
G5□□□-E1Z200	1.96	200	0.49	50	1.6	0.8	0.4	14.7±0.5
G5□□□-E1Z300	2.94	300	0.74	75	1.6	0.8	0.4	14.7±0.5
G5□□□-E1Z400	3.92	400	0.98	100	1.6	0.8	0.4	14.7±0.5

01 Short Straight Lever

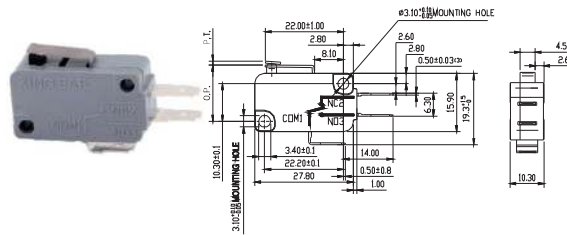

Part No.	Parameters							
	OF Max. (N)	OF Max. (gf)	RF Min. (N)	RF Min. (gf)	PT Max. (mm)	OT Min. (mm)	MD Max. (mm)	OP (mm)
G5□□□-E1Z015A01	0.15	15	0.03	3	1.6	0.8	0.4	15.3±0.5
G5□□□-E1Z025A01	0.25	25	0.05	5	1.6	0.8	0.4	15.3±0.5
G5□□□-E1Z050A01	0.49	50	0.10	10	1.6	0.8	0.4	15.3±0.5
G5□□□-E1Z100A01	0.98	100	0.25	25	1.6	0.8	0.4	15.3±0.5
G5□□□-E1Z200A01	1.96	200	0.49	50	1.6	0.8	0.4	15.3±0.5
G5□□□-E1Z300A01	2.94	300	0.74	75	1.6	0.8	0.4	15.3±0.5
G5□□□-E1Z400A01	3.92	400	0.98	100	1.6	0.8	0.4	15.3±0.5

02 Standard Straight Lever

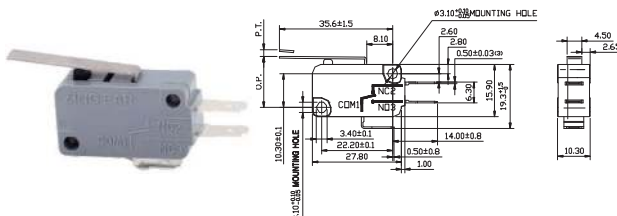

Part No.	Parameters							
	OF Max. (N)	OF Max. (gf)	RF Min. (N)	RF Min. (gf)	PT Max. (mm)	OT Min. (mm)	MD Max. (mm)	OP (mm)
G5□□□-E1Z015A02	0.15	15	0.03	2	3.2	1.3	1.2	15.3±1.5
G5□□□-E1Z025A02	0.25	25	0.05	2	3.2	1.3	1.2	15.3±1.5
G5□□□-E1Z050A02	0.49	50	0.10	5	3.2	1.3	1.2	15.3±1.5
G5□□□-E1Z100A02	0.98	100	0.25	10	3.2	1.3	1.2	15.3±1.5
G5□□□-E1Z200A02	1.96	200	0.49	20	3.2	1.3	1.2	15.3±1.5
G5□□□-E1Z300A02	2.94	300	0.74	30	3.2	1.3	1.2	15.3±1.5
G5□□□-E1Z400A02	3.92	400	0.98	40	3.2	1.3	1.2	15.3±1.5

03 Long Straight Lever

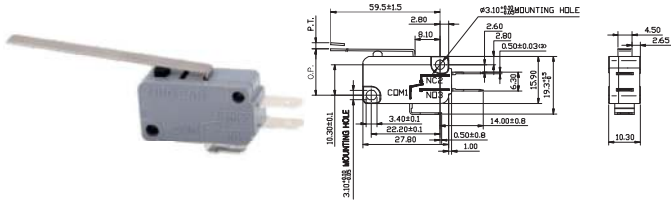

Part No.	Parameters							
	OF Max. (N)	OF (gf)	RF Min. (N)	RF (gf)	PT Max. (mm)	OT Min. (mm)	MD Max. (mm)	OP (mm)
G5□□□-E1Z015A03	0.07	7	0.02	2	6.4	2.6	2.4	15.3±3
G5□□□-E1Z025A03	0.10	10	0.02	2	6.4	2.6	2.4	15.3±3
G5□□□-E1Z050A03	0.15	15	0.02	2	6.4	2.6	2.4	15.3±3
G5□□□-E1Z100A03	0.29	30	0.05	5	6.4	2.6	2.4	15.3±3
G5□□□-E1Z200A03	0.59	60	0.10	10	6.4	2.6	2.4	15.3±3
G5□□□-E1Z300A03	0.88	90	0.15	15	6.4	2.6	2.4	15.3±3
G5□□□-E1Z400A03	1.18	120	0.20	20	6.4	2.6	2.4	15.3±3

05 Short Roller Lever

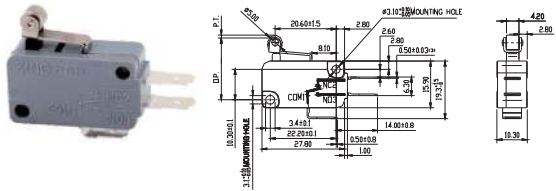

Part No.	Parameters							
	OF Max. (N)	OF (gf)	RF Min. (N)	RF (gf)	PT Max. (mm)	OT Min. (mm)	MD Max. (mm)	OP (mm)
G5□□□-E1Z015A05	0.15	15	0.03	3	1.6	0.8	0.4	20.6±0.8
G5□□□-E1Z025A05	0.30	30	0.05	5	1.6	0.8	0.4	20.6±0.8
G5□□□-E1Z050A05	0.59	60	0.10	10	1.6	0.8	0.4	20.6±0.8
G5□□□-E1Z100A05	1.18	120	0.20	20	1.6	0.8	0.4	20.6±0.8
G5□□□-E1Z200A05	2.35	240	0.39	40	1.6	0.8	0.4	20.6±0.8
G5□□□-E1Z300A05	3.43	350	0.59	60	1.6	0.8	0.4	20.6±0.8
G5□□□-E1Z400A05	4.60	470	0.78	80	1.6	0.8	0.4	20.6±0.8

06 Long Roller Lever

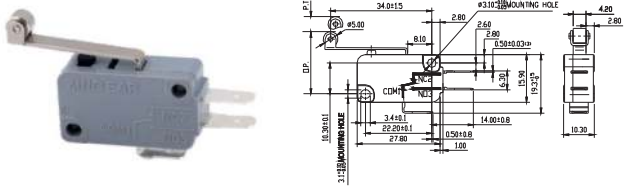

Part No.	Parameters							
	OF Max. (N)	OF (gf)	RF Min. (N)	RF (gf)	PT Max. (mm)	OT Min. (mm)	MD Max. (mm)	OP (mm)
G5□□□-E1Z015A06	0.10	10	0.02	2	3.2	1.3	1.2	20.6±1.6
G5□□□-E1Z025A06	0.15	15	0.02	2	3.2	1.3	1.2	20.6±1.6
G5□□□-E1Z050A06	0.29	30	0.05	5	3.2	1.3	1.2	20.6±1.6
G5□□□-E1Z100A06	0.59	60	0.10	10	3.2	1.3	1.2	20.6±1.6
G5□□□-E1Z200A06	1.18	120	0.20	20	3.2	1.3	1.2	20.6±1.6
G5□□□-E1Z300A06	1.77	180	0.29	30	3.2	1.3	1.2	20.6±1.6
G5□□□-E1Z400A06	2.35	240	0.39	40	3.2	1.3	1.2	20.6±1.6

Pin Plunger, 250# Terminals

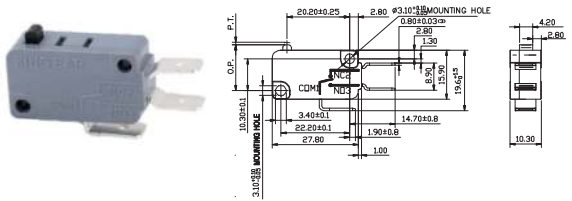

Part No.	Parameters							
	OF Max. (N)	OF (gf)	RF Min. (N)	RF (gf)	PT Max. (mm)	OT Min. (mm)	MD Max. (mm)	OP (mm)
G5□□□-C1Z015	0.15	15	0.03	3	1.6	0.8	0.4	14.7±0.5
G5□□□-C1Z025	0.25	25	0.05	5	1.6	0.8	0.4	14.7±0.5
G5□□□-C1Z050	0.49	50	0.10	10	1.6	0.8	0.4	14.7±0.5
G5□□□-C1Z100	0.98	100	0.25	25	1.6	0.8	0.4	14.7±0.5
G5□□□-C1Z200	1.96	200	0.49	50	1.6	0.8	0.4	14.7±0.5
G5□□□-C1Z300	2.94	300	0.74	75	1.6	0.8	0.4	14.7±0.5
G5□□□-C1Z400	3.92	400	0.98	100	1.6	0.8	0.4	14.7±0.5

Pin Plunger Basic Type Housing, 250# Terminals

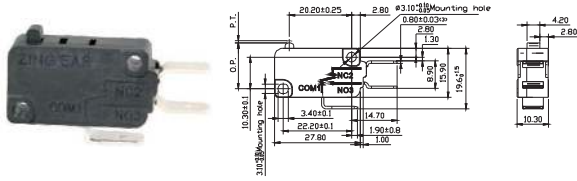

Part No.	Parameters							
	OF Max. (N)	OF (gf)	RF Min. (N)	RF (gf)	PT Max. (mm)	OT Min. (mm)	MD Max. (mm)	OP (mm)
G5□□□-CZ015	0.15	15	0.03	3	1.6	0.8	0.4	14.7±0.5
G5□□□-CZ025	0.25	25	0.05	5	1.6	0.8	0.4	14.7±0.5
G5□□□-CZ050	0.49	50	0.10	10	1.6	0.8	0.4	14.7±0.5
G5□□□-CZ100	0.98	100	0.25	25	1.6	0.8	0.4	14.7±0.5
G5□□□-CZ200	1.96	200	0.49	50	1.6	0.8	0.4	14.7±0.5
G5□□□-CZ300	2.94	300	0.74	75	1.6	0.8	0.4	14.7±0.5
G5□□□-CZ400	3.92	400	0.98	100	1.6	0.8	0.4	14.7±0.5

Pin Plunger Basic Type Housing, 187# Terminals

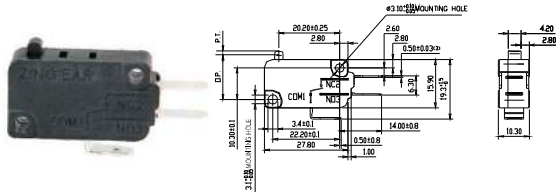

Part No.	Parameters							
	OF Max. (N)	OF (gf)	RF Min. (N)	RF (gf)	PT Max. (mm)	OT Min. (mm)	MD Max. (mm)	OP (mm)
G5□□□-EZ015	0.15	15	0.03	3	1.6	0.8	0.4	14.7±0.5
G5□□□-EZ025	0.25	25	0.05	5	1.6	0.8	0.4	14.7±0.5
G5□□□-EZ050	0.49	50	0.10	10	1.6	0.8	0.4	14.7±0.5
G5□□□-EZ100	0.98	100	0.25	25	1.6	0.8	0.4	14.7±0.5
G5□□□-EZ200	1.96	200	0.49	50	1.6	0.8	0.4	14.7±0.5
G5□□□-EZ300	2.94	300	0.74	75	1.6	0.8	0.4	14.7±0.5
G5□□□-EZ400	3.92	400	0.98	100	1.6	0.8	0.4	14.7±0.5

IP64 Waterproof switch



Part No.	Parameters							
	OF Max. (N)	OF (gf)	RF Min. (N)	RF (gf)	PT Max. (mm)	OT Min. (mm)	MD Max. (mm)	OP (mm)
G5F**-C1Z300	2.94	300	0.74	75	1.6	0.8	0.4	14.7±0.5

04 Simulated Roller Lever

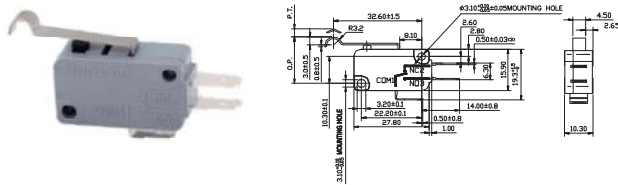

Part No.	Parameters							
	OF Max. (N)	OF (gf)	RF Min. (N)	RF (gf)	PT Max. (mm)	OT Min. (mm)	MD Max. (mm)	OP (mm)
G5□□□-E1Z015A04	0.10	10	0.02	2	3.2	1.3	1.2	18.3±1.5
G5□□□-E1Z025A04	0.15	15	0.02	2	3.2	1.3	1.2	18.3±1.5
G5□□□-E1Z050A04	0.29	30	0.02	2	3.2	1.3	1.2	18.3±1.5
G5□□□-E1Z100A04	0.59	60	0.10	10	3.2	1.3	1.2	18.3±1.5
G5□□□-E1Z200A04	1.18	120	0.20	20	3.2	1.3	1.2	18.3±1.5
G5□□□-E1Z300A04	1.77	180	0.30	30	3.2	1.3	1.2	18.3±1.5
G5□□□-E1Z400A04	2.35	240	0.39	40	3.2	1.3	1.2	18.3±1.5